

Discussion on preceding two papers.

Dr. J. Daams I am glad I am offered the opportunity to make some comment on Dr. Barnsley's paper. As you know, we discovered the activity of this compound independently in Holland. I regret that I have so few comments to make for if we had presented a paper on this compound it would have been of striking similarity. We have found it extremely promising for the control of bracken frond and we found it highly promising on Panicum in rice.

Dr. W. van der Zweep It might be interesting to give some more details on the action of 2,6-DBN on bracken. We did not bring this into the discussion during the session on bracken because there the stress was on translocated chemicals - 4-CPA, amino triazole and dalapon and these have to be applied on the foliage. On the continent, bracken is a forestry problem and often chemicals have to be applied selectively. According to the experience of my colleague Mr. Zonderwijk of the Plant Protection Service, 2,6-DBN has not to be applied to the foliage but as a pre-emergence spray or early post-emergence spray (when the first frond is expanding). Treatments give a practical control during the year of application, making cutting unnecessary. Control in the year after application is not complete but considering the apparent resistance of established trees to the chemical, repeated applications may be possible.

Mr. P. A. Thompson I should like to ask Mr. Barnsley if he would enlarge on the physical, chemical and biological properties of 2,6-DBN which results in the dramatic increase in its half-life when application is followed by irrigation or light cultivation.

Mr. G. E. Barnsley The most important factors are thought to be the high vapour pressure and low water solubility of 2,6-DBN. Both cultivation and sprinkle irrigation appear to reduce loss of the compound by volatilisation, presumably by removing a substantial proportion of the compound from the soil surface. The low water solubility of 2,6-DBN apparently precludes extensive movement downwards, and loss by leaching.

Mr. J. G. Elliott Could Mr. Barnsley enlarge a little on the chemical's effects on deep rooted perennials. Has he tried it on established pasture grasses?

Mr. G. E. Barnsley We have no evidence that 2,6-DBN is translocated to any appreciable extent from leaf to root or rhizome. The control of perennial weeds appears to depend on root uptake and subsequent inhibition of bud and shoot growth, as I have illustrated in my paper in the case of Agropyron and Aegopodium. We have not evaluated 2,6-DBN on established pasture grasses.

Miss J. D. Westley You have commented on the appreciable volatility of the compound. In the seed germination experiment do you consider any loss of 2,6-DBN could be due to including acetone in the solution and of its evaporating from the solvent?

Mr. G. E. Barnsley This loss is a possibility. If it were appreciable we have in fact underestimated the activity of 2,6-DBN in this experiment. However for various reasons I do not consider that a significant loss of 2,6-DBN occurred.

Mr. S. Campbell If the use of irrigation or heavy rainfall tends to increase the persistence of the chemical, possibly by removing it from the soil surface, to what extent might surface cultivation help to counter this?

Mr. Barnsley Our experiments have so far been confined to an initial cultivation after spraying and this has consistently extended the persistence of 2,6-DEN. If anything cultivation and irrigation are additive.

DIQUAT - A REVIEW OF RESEARCH AND DEVELOPMENT
WITH THE COMPCUND, 1955-1960

H. P. Allen

Plant Protection Ltd.

INTRODUCTION

Several papers have been published in which laboratory, greenhouse, and field studies with diquat and related compounds are described in detail (Brian R. C. et al. 1958; Homer R. F. et al, 1960; Stubbs J. 1958). These papers cover chemical and physiological aspects of the action of diquat and outline some of the likely uses of dipyridyls in agriculture and horticulture.

The object of this paper is to review these studies as a whole and to present to this Conference as complete a picture of diquat as present knowledge will permit. In compiling the paper the writer has drawn freely upon the material contained in the publications referred to above and makes grateful acknowledgement to the authors thereof.

INITIAL INVESTIGATIONS

It is already known (Brian R. C. et al. 1958) that diquat (the coined common name for 1:1'ethylene - 2:2' dipyridylum dibromide) was first noted as a chemical of exceptional activity early in 1955 during an investigation at Jealott's Hill Research Station into the herbicidal properties of a series of quaternary ammonium compounds. Diquat was first prepared by R. J. Fielden at Dyestuffs Division (I.C.I.) Laboratories at Blackley by the quaternization of 2:2' dipyridyl with ethylene dibromide, a reaction which produces a well-defined crystalline product of the formula mentioned above. The structural formula for diquat is:-

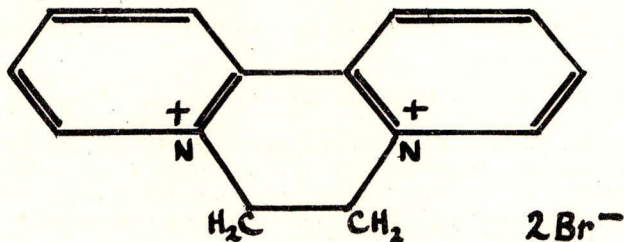

Diquat forms a pale yellow monohydrate from water, is readily soluble to the extent of 70 g in 100 ml water at 20°C., and is stable in acid or neutral solution. In alkaline solution diquat is less stable and coloured complex products are formed which appear to arise from the opening of one of the pyridine rings, a process associated with the uptake of one molecule of alkali (Brian R. C. et al. 1958).

In their letter to "Nature" (Brian R. C. et al. 1958) these workers describe greenhouse studies in 1955 in which diquat, applied as a foliage spray in aqueous solution with 0.3 per cent v/v of a wetting agent ('Agral' LN) added to the diluted spray, gave complete kill of sugar beet, wheat, white mustard, marigold, red clover and cleavers at doses down to 0.5 lb per ac of diquat in 100 gal total spray/ac.

The 0.25 lb/ac rate gave 100 per cent kill of marigold, nearly complete kill of mustard, and even at 0.125 lb/ac diquat seriously damaged all the test plants mentioned with the exception of cleavers. Without the wetter, also at low-volume (20 gal/ac) applications, diquat gave very similar results. It was noticeable also that the action of diquat on the plant was very rapid.

This apparent independence of volume of application of diquat as a foliage spray suggested systemic activity and the uptake and translocation of the compound through the aerial parts of broad beans and oats was readily demonstrated, and confirmed by use of material labelled with ^{14}C .

Root uptake by oats growing in culture solutions occurred but applications to the soil around the bases of full grown plants had no effect on the plants; further investigations in this direction showed that diquat was instantaneously adsorbed and immediately inactivated in soil.

Thus by the end of 1955 the following properties of diquat were apparent:-

1. The compound is very rapidly absorbed into plant foliage and there is movement through the aerial parts of plants.
2. Partly due to its systemic activity diquat is as effective when applied low volume (at least down to 20 gal water/ac) as in high volume applications.
3. Diquat is highly active against a number of annuals under greenhouse conditions at rates of application down to 0.125 lb/ac. Its action indicates considerable potential for the compound as a herbicide and desiccant.
4. Diquat is adsorbed immediately on contact with the soil by base exchange.

The next steps in the investigation were now clear. These were:-

1. To continue field tests to define more clearly the properties of diquat both as a herbicide and as a desiccant in the field. This study would embrace tests of the compound with various wetting agents and alone, at different doses and volumes on a wide range of crops and weeds both in Britain and overseas.
2. To set up chemical and physiological work with the object of throwing light on the mode of action of diquat.

These two lines of investigation were followed simultaneously by teams of biologists and chemists; in this paper the studies concerning mode of action of diquat will be dealt with first and the biological field investigations will be described later.

STUDIES ON MODE OF ACTION

The unique properties of diquat which revealed themselves in the biological tests of 1955 led to the examination in the period 1956 - 1960 of a range of quaternary salts derived from heterocyclic systems related to 2:2'dipyridyl, in particular those salts derived from possible isomeric dipyridyls, with the object of (a) determining the chemical requirements for the appearance of the type of phytotoxic activity displayed by diquat, and (b) elucidating the mode of action of these compounds.

These studies are described in detail by Homer, Mees and Tomlinson in their paper to the Pesticides Group of the S.C.I., read in February 1960. The main points arising from this work are as follows:-

The activity of the dipyridyl quaternary salts depends on the reversible production in the plant of a free radical. This is formed from the quaternary salt by reduction, namely the uptake of one electron, at biological redox potentials, and within the limits set by these potentials, the more readily the chemical is reduced the more active it will be.

It was possible to confirm this hypothesis by comparing the redox potentials of a number of these compounds with their biological activity. Thus the 2:2' and 4:4' dipyridylium salts are the most easily reduced; they are also the most biologically active. In contrast it is not possible to reduce the 2:3' and 3:3' dipyridylium salts and these are inactive. Further, certain substituted 2:2' salts are more difficult to reduce than diquat and are proportionately less active. Light appears essential for this rapid killing effect of diquat. Plants treated in the dark take longer to die if they are kept in the dark than if they are transferred to the light. This would suggest that the necessary redox potentials are developed in normal respiration processes, but a more rapid reduction occurs during active photosynthesis. Translocation of the chemical continues efficiently in the dark and when "dark" treated plants are brought out into the light the aerial parts die rapidly.

It has been mentioned earlier that diquat acts very rapidly on the aerial parts of plants. It is well to enlarge upon this point because it is this aspect of activity which is most striking. In plants sprayed with diquat in the light the death of the leaves is extremely rapid; effects are frequently visible in less than an hour and the treated leaves are completely desiccated in a very few days. Stem tissues, e.g. potato stems, die more slowly and it is more likely that here death follows the slow diffusion of the chemical into healthy tissue.

The result of the very rapid 'contact' kill of the leaves of plants by diquat is to kill the translocating mechanism, but a very small amount of diquat is moved from leaves down the stems by passive translocation. Amounts of diquat moved downwards in this way are just sufficient to produce detectable residues in underground parts of plants, e.g. potato tubers, but far too low to have any herbicidal effect, and 'kill' of the plant by diquat normally stops at soil level giving an effect similar to cutting or burning. It follows that treated perennial plants will recover, some more slowly than others.

There are two more aspects of diquat which should be mentioned here, namely residues and mammalian toxicity.

Residue analyses of large numbers of potato tubers harvested from potatoes where haulms were treated with diquat have shown residues ranging from 0.05 ppm to 0.1 ppm. This is consistent with the known lack of effect of diquat on those parts of plants below soil level.

Diquat has a low oral mammalian toxicity to rats, the oral LD 50 being 400 - 440 mg/kg, and 500 ppm w/w of diquat in the daily diet of rats for sixteen months did not affect the rate of growth during the period, nor was any chronic toxicity apparent.

FIELD USES FOR DIQUAT

When considering the role of diquat we should start from the point that it is a contact herbicide and desiccant with an extremely rapid action with absolutely no activity in the soil and with a low mammalian toxicity.

For a desiccant, potato haulm, legume seed crops and cotton are obvious outlets, and considerable work has been carried out with the compound on these crops.

In cotton doses of diquat as low as 0.75 - 1.0 lb/ac in low volumes of water (5 - 15 U.S. gal/ac) have given acceptable desiccation of 'stripper' type cotton in Texas, comparable with the arsenic acid and pentachlorophenol sprays currently in commercial use there. On Lucerne in California diquat at 1 - 1.25 lb/ac has compared very favourably with dinoseb, and on white, red and crimson clover has proved an effective desiccant at doses of from 0.5 - 1.5 lb/ac. In England trials up to 1959 indicated that diquat at 1 - 1.5 lb/ac gives satisfactory desiccation of red clover seed crops and large-scale trials are in progress this year (1960) to confirm these results.

In Australia diquat is proving of considerable utility as a "preburning" desiccant of forest fire breaks. The young spring growth is desiccated by diquat and rendered sufficiently dry for controlled burning before the remainder of the vegetation in the forest area is tinder-dry and inflammable. It may be possible to extend this technique to maintenance of rights of way and of fire breaks in rangeland.

In British Guiana, where sugar cane foliage is burnt before harvest and where moist weather often renders this operation difficult diquat has been tried with success as a pre-burning desiccant at rates of 1 - 2 lb/ac.

The use of diquat as a contact weedkiller may be envisaged although its complete lack of residual activity limits it as a pre-emergence weedkiller in the normally accepted sense, it can be used successfully wherever annual weeds are present and the crop has either not been sown or has not emerged. The application of diquat to a weedy seedbed could be delayed with safety until the first "pioneer" seedlings of the sown crop begin to emerge.

An ideal medium for diquat is in late autumn as a treatment to remove chickweed (*Stellaria media*) and other annuals from daffodil and tulip beds and anemone beds before the new shoots come through the ground. The killing of "trash" in bulb beds before lifting in late summer is another possible use for diquat.

In total weedkilling diquat has shown itself effective in two ways (a) where top kill but not root kill is desired, i.e. on ditch banks where roots bind the soil and prevent erosion, and (b) in combination with substituted ureas and/or simazine to give a quick knock-down of the treated herbage. In situations where grass weeds are predominant, however, other dipyridyl compounds are proving more effective than diquat. Mr. Jeater has dealt with one of these (4:4' dipyridyl) in his paper given in session VI of this Conference.

In the field of aquatic weed control diquat has shown promise in screening tests and small plot trials for the treatment of submerged aquatics, but more work remains to be done before much can be said of diquat in this role. Diquat has also shown promise as an algicide and in one test diquat, sprayed into a flowing canal to give a concentration of about 13 ppm for ten minutes, cleared *Cladophora* completely from the canal near the point of treatment, and the effects were visible for about 1,000 feet downstream.

Finally, whilst diquat cannot really be looked upon as a selective herbicide in the true sense of the word, in general the compound is more active against broad-leaved weeds than against grasses and even within the graminæ there is a range of susceptibility. In cereals for example, oats will tolerate an application of 1.5 lb diquat/ac while a dose of 0.5 lb /ac will damage barley. The degree of scorch by diquat, even on the tolerant oats, rules it out for all practical purposes however.

It is not possible in a paper of this size to offer detailed results of experiments nor is it the object so to do. It is hoped that this general review will help the reader to gain a good general impression of the properties of this new compound.

REFERENCES

- BRIAN R. C. et al. (1958), "A New Herbicide - 1:1' ethylene-2:2' dipyridylum dibromide", *Nature*, 181, 446 - 447.
- HOMER R. F. et al. (1960), "Mode of Action of Dipyridyl Quaternary Salts as Herbicides", *J. Sci Fd Agric*, 11, 309 - 315.
- STUBBS J. (1958), "A New Herbicide", *Outlook on Agriculture*, 2, 64 - 66.

Discussion on preceding paper

Mr. J. Macfarlan I would like to know, for potatoes in Scotland, what would be the recommended dose of diquat and the volume rate for both ground and aerial applications.

Dr. H. P. Allen Last year we had reached the peak of our field trials, in one of the driest seasons for many years. One can never trust completely the results of trials carried out under such conditions. Although we had a fairly clear idea as to the doses for best results, we wished to confirm these in our larger-scale trials this year. The results that we have obtained certainly appear to confirm the results which we achieved in 1958 and 1959. The optimum dose range is $1\frac{1}{2}$ to 2 lb diquat/ac. $1\frac{1}{2}$ lb might prove successful, but there may be cases when the higher dose might be necessary. Trials confirm that a volume rate of $2\frac{1}{2}$ to 3 gal/ac is successful with aerial application both by helicopter and fixed wing aircraft. The results obtained were indistinguishable from ground machines.

Mr. J. Zwijns I think there is an error of thinking when you talk about desiccants and haulm killers. When we use desiccants we want to take away the leaves and keep the stem but with haulm killers we want to kill the stem as well. I would say the chemical we are talking about is a good desiccant but on Dutch evidence not a good haulm killer.

Dr. H. P. Allen I am very well aware of the Dutch conditions. In the U.K. when one is growing crop predominantly for seed one wants to arrest growth as quickly as possible. With ware potatoes, again the object is to get complete kill of leaf and stem, but not necessarily the 3-day leaf and stem kill which seems to be a feature of Dutch seed potato growing. Haulm killers of fairly rapid action on the leaves all take within the general range of 10 to 15 days to produce complete stem kill. This generalisation may be a little unfair to sulphuric acid. Under our conditions we are eminently satisfied with the performance of diquat but for Dutch conditions I doubt whether any single chemical can satisfy the extremely stringent requirement.

Mr. J. G. Elliott This year we used diquat to desiccate green weed in laid ripe barley. This enabled us to combine the barley and resulted in a cleaner, drier sample. What does Dr. Allen think of this technique and is the grain likely to be affected in any way?

Dr. van der Zweep Have you any data on the quality of the water - its content of mud and organic matter - on the effect of diquat.

Dr. H. P. Allen With reference to Mr. Elliott's question, my personal view is that the chances of having any diquat in the grain would be extremely small and in any case I think that any effect on such grain would again be very small. That is my personal opinion.

In reply to Dr van der Zweep, it is our view that the organic content of water would be a direct factor in influencing the residual activity of diquat in that water. If muddy, the chance of diquat being adsorbed on to mud particles is very high. In irrigation the chance of flooding over land a dilute solution of free diquat is extremely low because irrigation water must acquire a fair amount of organic matter "en route".

A TECHNIQUE FOR THE APPLICATION OF PRE-EMERGENCE HERBICIDES

ON SUGAR BEET

B. H. Bagnall, J. J. B. Caldicott and D. J. Minter

The Murphy Chemical Company Limited, Wheathampstead, St. Albans, Herts.

Summary: A prototype machine for the application of endothal and prophan pre-emergence weedkiller on sugar beet has been developed, enabling the spray application to be applied at the time of drilling. A band of spray 7 in. wide was applied directly over the row after the seed had been drilled. The row was thus rendered free of weed during the critical post-drilling period for 3 or 6 weeks. This factor, together with the combination of precision drilled triploid monogerm seed followed by mechanical thinning, has been exploited with a view to undertaking a completely mechanised spring programme.

INTRODUCTION

A reduction in the demand for farm labour can be achieved by using a good precision seeder with suitable seed and following with mechanical thinning. However, the constant but thinly spaced braird produced by the precision seeder, is more vulnerable to weed competition than that obtained from the long established method of drilling natural seed at a fairly heavy seed rate.

A normal means of reducing weeds is during seed bed preparation which often results in delayed sowing and loss of moisture. Later in the season, inter-row weed control can be mechanical but intra-row control is of paramount importance due to the vulnerability of the thinly spaced crop and the expense of removing the weeds. The problem of intra-row weed control lends itself to the development of a chemical herbicide which will keep the crop clean throughout the critical period between drilling and thinning. Application of the chemical as a band spray reduces the cost whilst still dealing with the most important weeds.

Twenty one trials were laid down in the spring of 1960 with the aim of a completely mechanised spring programme, without any hand labour, by using an endothal and prophan mixture sprayed in a band as a pre-emergence treatment on sugar beet.

If the aim of a programme such as this is to be fully realised, the ideal need is for a good precision seeder, mechanical thinner and a reliable triploid monogerm seed, which will give a constant braird containing a high percentage of singles.

METHODS AND MATERIALS

The Machine

The prototype machine used for the field applications of endothal and prophan consisted of a P.T.O. operated five-row seed spacing drill which was mounted on the three-point linkage of the tractor. The spraying machine consisted of a 60 gal tank on special mounting brackets, enabling it to clear the drill, a 12 gal/min rollervane pump with sufficient capacity and lift to fill the

somewhat elevated tank, and drop arms holding the nozzles mounted to the framework of each of the drill units. Special low pressure, no-drift nozzles were adapted for the application and arranged so as to give a spray band seven inches wide, directly on top of the row, each nozzle giving an output of 8 fl oz/min at 16 psi.

Laboratory tests were carried out on the nozzles to determine the distribution of the herbicide from the 7 in. band. For this purpose a colourimetric determination was used. Large filter papers were sprayed with a 5 per cent solution of a salt of chicao red dye. Each paper was cut into 10 strips which were analysed separately by extracting the dye with boiling water. The dye extract from each strip was diluted to a constant volume until it could be matched with standard solutions containing $\frac{1}{2}$, 1 and $1\frac{1}{2}$ ppm of the dye. By this means the spray spectrum was determined and distribution of the dye found to be fairly constant across the width of the band.

The out-put of the machine was 21 gal/ac on an overall spray basis, but by the band technique, approximately one third of the area was in fact sprayed and the actual application was 7 gal/ac.

To achieve the correct spray volume, the forward speed of the tractor was fixed at 2 mph but this can easily be adapted to 3 mph for faster drilling.

A control gear operated by a rod fixed to the machine, within easy reach of the operator, ensured that the spray could be shut off at the headlands whilst the machine was positioned to drill the following bout. Hence there was no need for the operator to disengage the P.T.O. drive.

It will be obvious that the virtue of such a machine is that it enables drilling and spraying of the selective herbicide to be carried out in one operation thus dispensing with a post-drilling spray programme. Ripper W. E. (1957) has described the use of a similar machine for selective weed control in beet whereby the germinating beet seedlings have been protected from semi-selective herbicides by an adsorbent layer of charcoal. A 6-12 in. band of herbicide was sprayed directly over a consolidated seed furrow in which the adsorbent lay mid-way between seed and soil surface.

Owing to the toxicity of endothal, all possible precautions have been taken in machine design to prevent the accidental contamination of the operator. To this end a deflector shield was fitted between the tank and the operator. Tests have been undertaken where a dilute phosphate solution has been employed as an indicator to determine the degree of spray drift. The test solution was potassium dihydrogen phosphate with enough phosphoric acid to give sufficient acidity to effect a change in congo red indicator paper. The concentrate, containing 10.8 per cent phosphorus, was diluted at the rate of $\frac{1}{2}$ gal to 30 gal yielding $\frac{10.8}{60} = 0.18$ per cent phosphorus.

60

A number of 9 cm filter papers treated for half their area with congo red indicator were fastened to the front and rear of the seeder frame, and the mud-guard, three point linkage and rear of the tractor. The indicator treated half of the papers were used to assess the contamination visually whilst, for analytical purposes, the untreated halves were cut off, and extracted. In addition, a white cotton boiler suit, muslin cowl-type head covering and cotton gloves worn by the tractor driver were analysed for phosphorus. The total

phosphorus was determined by a method described by Kitson R. E. and Mellon M. G. (1944).

Results from these tests indicate that the operator was in no danger of contamination. Drift generally was reduced to a very low level due to -

- (a) the low pressure no-drift nozzles
- (b) the relatively close position of the nozzles to soil surface, necessary to maintain a 7 in. spray band.

The Weedkiller

Di-sodium endothal and propham were formulated as a combined emulsion in the proportion 4 : 3 acid equivalent. Three doses were used. The combined emulsion was mixed in suitable quantities of water so as to give these doses when applied at 7 gal/ac of dilution (on the basis of a 7 in. band).

Seed Type

Triplex M monogerm seed was compared in each trial with seed, supplied by the farmer, which was always 8-10/64ths gravity separated. In all instances, both types were drilled at 1½ in. spacing. Due to the smaller flatter shape of the monogerm seed, differing seed belts were used for each type; a number 14 seed belt for the Triplex and number 15 for seed provided by the farmer.

Emergence data from the trials carried out this season showed the Triplex M monogerm seed gave 79.3 per cent singles as compared with 63.5 per cent singles in the 8-10/64ths gravity separated seed.

RESULTS

Biological results obtained from the experimental work using this technique are presented by the authors elsewhere. (Bagnall B. H. et al 1960).

Acknowledgements

Acknowledgements are due to the directors and personnel of the various companies whose co-operation and advice have been invaluable - The Dorman Sprayer Co. Ltd., for the development of the band sprayer, Stanhay (Ashford) Ltd., for supplying the seed-spacing drill; Bush Johnsons Ltd., who provided the Triplex M monogerm seed and S.K.H. & Son (Salopian-Kenneth Hudson & Son) for supplying a Down-the Row Thinner.

REFERENCES

- BAGNALL B. H., CALDICOTT J. J. B., and MINTER D. J. (1960). Field trials with endothal and propham for the control of seedling weeds in sugar beet. 5th Brit Weed Control Conf, 1960. (Session II).
- KITSON R. E., and MELLON M. G. Colorimetric determination of Phosphorus as Molybdivanadophosphoric acid. Ind and Eng Chem anal Ed. June 1944 16, No. 6 p. 379.
- RIPPER W. E., (1957). A new method of selective weed control for related plants, in particular broad leaved weeds in beet. Proc. 3rd Brit Weed Control Conf, p. 225-232.

THE SPRAY-INCORPORATING DRILL. A MACHINE
DESIGNED TO IMPROVE THE RELIABILITY OF SOIL-ACTING HERBICIDES.

J. D. Fryer, C. Parker,* E. K. Woodford

Agricultural Research Council Weed Research Organisation, Oxford.

*A.R.C. Unit of Experimental Agronomy.

Summary: an attempt is being made to increase the reliability of soil-acting herbicides for the control of annual weeds in drilled row-crops by the development of a machine which performs the following operations: i) applies the herbicide, ii) incorporates the herbicide with the soil in bands 9 in. wide, iii) compacts the soil after incorporation, iv) sows a crop. Preliminary trials have indicated that the machine produces a seed-bed favourable for emergence and growth of a number of crops and that several herbicides show promising selectivity when incorporated immediately prior to sowing. Much more work is required before the practical importance of the technique can be assessed, and in particular, information is required on the degree of incorporation brought about by rotary cultivation.

INTRODUCTION

Soil-acting selective herbicides used to control annual weeds during the early stages of growth of drilled crops are applied either prior to sowing the crop (pre-sowing application) or soon afterwards (pre-emergence).

Pre-sowing applications are at present confined to herbicides which require incorporation with the soil if they are to give effective weed control, e.g TCA for the control of *Avena fatua*. In farming practice the nature of the incorporation and the time at which it is carried out are likely to vary according to the implements available to the farmer, the time he has at his disposal, the weather and the state of the soil. The efficiency of the herbicide, however, and its selectivity to crop and weed are greatly influenced by the manner in which it is incorporated and by all the environmental and soil factors that can effect its distribution and stability in the soil during the interval between application and germination of the crop seed. Pre-sowing treatments as at present practised cannot therefore reach a high level of precision and considerable variation in results can be expected.

Similarly the results of pre-emergence treatments are also liable to vary. The interval between the preparation of the seed-bed and sowing the crop determines the stage of development of the germinating weeds and can affect their susceptibility. The interval between sowing and spraying influences the stage of development of the crop and its resistance to the herbicide. The weather and state of the seed-bed are most important factors determining the movement and stability of the herbicide in the soil and hence the concentration of herbicide in the neighbourhood of the germinating weed and crop seeds.

These and other factors interact and jointly determine the result obtained in the field. If the reliability of pre-sowing and pre-emergence treatments with soil-acting herbicides is to be improved, some method must be found which will allow control over as many of these factors as possible. With this object in view, a special machine, which has been called S.I.D. (Spray-incorporating Drill.) has been developed in conjunction with H. J. Hamblin and G. R. Chalmers of the National Institute of Engineering and with F. Rayns, A. F. Murrant and G. W. Cussans of the Norfolk Agricultural Station, Sprowston. The design of the machine has been influenced by the special requirement of a herbicide treatment for sugar beet and the interest in this subject at Sprowston. The principles on which the design is based are however relevant to the treatment of any row-crop with soil-acting herbicides. They may be summarised as follows: i) the time-interval between application of the herbicide and sowing the crop must be standardised and as short as possible, ii) the seed-bed must be as consistent as possible with the minimum of variation of physical factors influencing the distribution and stability of the herbicide in the soil, iii) the movement of the herbicide from the soil surface to the germinating weed-seeds must not be left to chance rainfall but must be determined by a standard method of incorporation, iv) the herbicides used must be sufficiently selective not to harm the crop even when in contact with the roots, 'artificial' selectivity resulting from differential placement of herbicide and crop playing no part in the treatment, v) the technique must be readily adaptable for commercial use by farmers and market gardeners.

DESCRIPTION OF THE EQUIPMENT

This description is based on a note prepared for J. Agric. Eng. Res V, 4, 1960, by Chalmers, G. R. and Kemp, D. C. of the N.I.A.E., Silsoe, who kindly made it available for the preparation of this report and who gave permission for the reproduction of fig. 1.

In its present form S.I.D is an experimental machine, which could be used as the basis for designing a production model for commercial use, particularly with sugar-beet. It is designed to apply the herbicide as required, to incorporate by means of a rotary cultivator the herbicide with the soil in bands 9 in. wide and 20 in. centre to centre, to consolidate the loose soil after incorporation thereby completing the formation of a 'standard' seed-bed, and finally to sow the crop by means of a precision seeder-unit. As at present constructed, it is limited to a single row to row spacing, to operation on only two rows simultaneously and to a rotor speed that is fixed in relation to ground speed by the power-take-off arrangements of the tractor to which the equipment is attached. There are no inherent difficulties in modifying the design to overcome all three limitations.

The layout and principle of operation of the equipment are shown diagrammatically in fig. 1. The machine is designed to be attached either to a Ferguson 20 or to a Massey-Ferguson 35 tractor. It is semi-mounted with two castor-wheels at the rear, an arrangement which gives manoeuvrability identical to that of fully mounted equipment. It is coupled conventionally to the tractor draught links with standard stabiliser bars fitted to prevent lateral movement. The drills are connected to the tractor top-link by means of a linkage which provides extra lift and ensures that the drills are clear of the ground when the cultivators are lifted out of work.

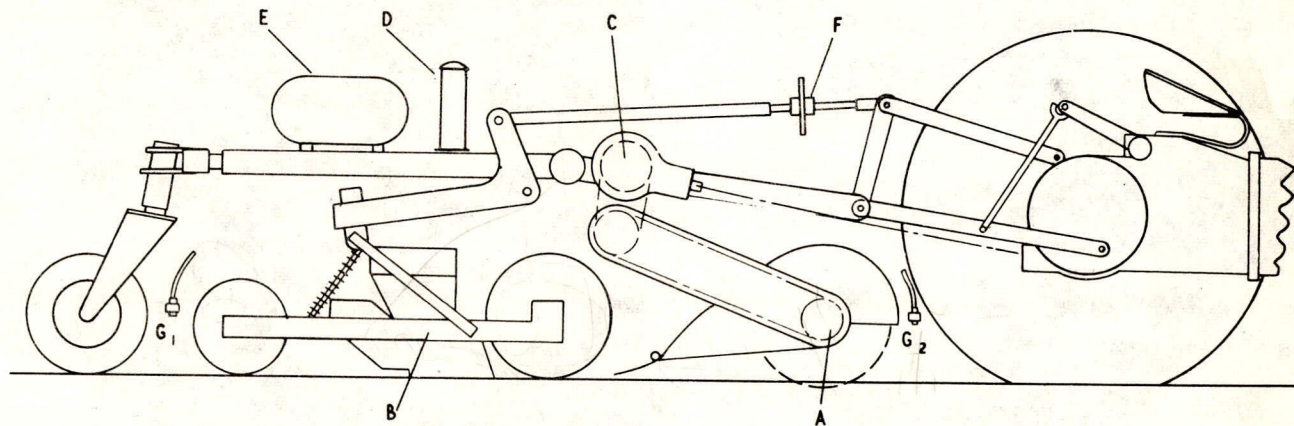

- A. Rotary Cultivator, (Howard 'Yeoman' Rotor Reduced to 9" wide).
- B. Stanhay Spacing Drill.
- C. Gear box.
- D. Spray Chemical Container.
- E. Air Cylinder.
- F. Drill Pressure Adjuster.
- G₁ & G₂ Alternative Nozzle Positions.

FIGURE 1. DIAGRAMMATIC LAYOUT OF THE SPRAY-INCORPORATING-DRILL.

(Reproduced by kind permission of the authors:
Chalmers, G. R. and Kemp, D. C. (1960) J. Agric Eng Rsch, 5, 4)

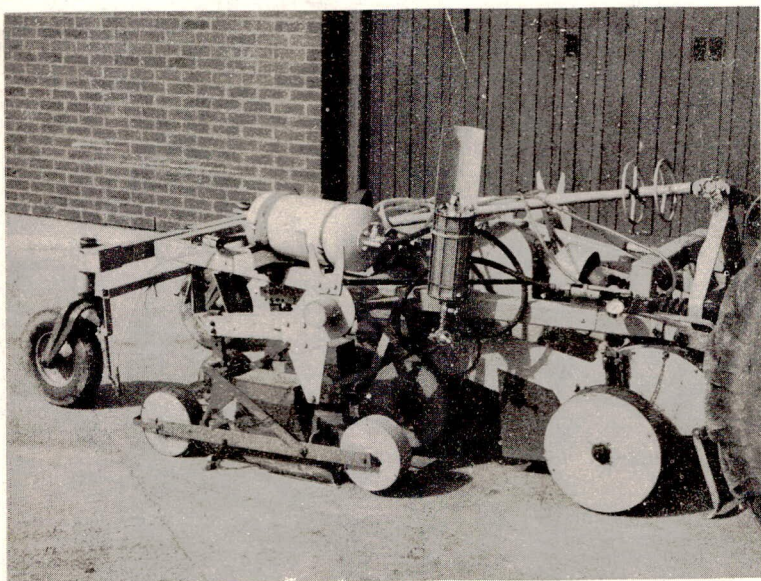
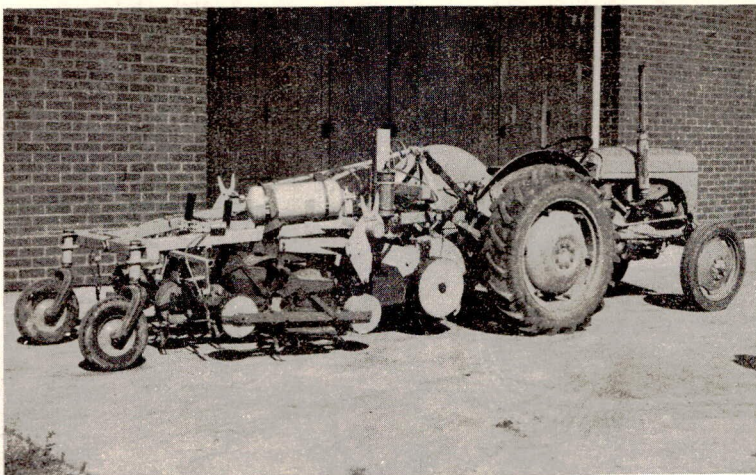

FIGURES 2 AND 3. GENERAL VIEWS OF THE SPRAY-
INCORPORATING-DRILL

The 9 in. wide rotary cultivators are fitted with L-shaped blades and are driven from the power take-off to give a rotor speed of 298 rpm corresponding to 4.6 cuts per foot travel at 1½ mph with the Ferguson 20 in first gear. Corresponding performance is obtained with the Massey Ferguson 35 in third gear. The cultivators can be individually set to work at depths from 0-4 in. in 1 in. stages by means of depth wheels. Alternatively, the height of the chassis can be determined by a mechanical stop or by the hydraulic control according to the tractor used. This greatly speeds up the work in the field if constantly varying depths are required.

The seed-drills are standard "Stanhay" precision seeder units except that larger front rollers 12 in. diameter and 12 in. wide are fitted to allow the drills to function efficiently and to give a satisfactory seed-bed. In addition to the normal adjustments on the seed-drills, a hand-wheel (F, fig. 1) is fitted in the lift-linkage to give a rapid adjustment of pressure on all the drills to cater for varying conditions.

The herbicide is applied by means of a modified Oxford Precision Sprayer mounted on the machine and controlled either by the tractor driver or an operator walking alongside. The nozzles are so positioned that a band of spray can be applied either in front of each rotary cultivator or behind each drill as required.

RESULTS

Trials with S.I.D. have been mainly concerned with improvements to the design and operation of the machine, and the stage has now been reached when only minor modifications are required to make this equipment suitable for serious experimental work. The testing of the prototype and all the work on sugar beet have been done at Sprowston by Dr. A. F. Murrant and G. W. Cussans. Trials involving a range of crops and herbicides have been undertaken by the Weed Research Organisation at Begbroke Hill Farm, near Oxford. At both places the soil is a light loam and the herbicides were incorporated in most cases to an estimated but unchecked depth of 1-2 in. with the rotor working 3-4 in. deep.

It would not be appropriate at this stage to comment in detail on the biological results obtained so far from these preliminary trials, but some interesting indications have been obtained.

The sowing of crops immediately after rotary cultivation is a feature of S.I.D. which is controversial to the extent that this practise might have some adverse effect on emergence and subsequent growth of the crop due to inadequate compaction and to loss of soil moisture. During the two seasons' tests (1959-60) there have, however, been no indications that this is likely to prove a serious problem. Impaired growth has, in fact, only been obtained in one trial: on sugar beet when moisture in the seed-bed was already marginal for germination and establishment.

Another promising feature of the trials has been the unexpectedly low incidence of serious crop damage resulting from incorporation, even though the herbicides must have been in contact with the roots of the crop plants over a long period. The herbicide treatments that have so far proved 'safe' when the depth of rotary cultivation was 3-4 in. are listed in Table 1.

TABLE I. A LIST OF CROPS SHOWING THE INCORPORATED HERBICIDE TREATMENTS WHICH HAVE NOT CAUSED APPRECIABLE CROP DAMAGE.

Crop.	Herbicide
Maize	simazine (2) atrazine (2) 2,4-D ester (1.5)
Carrots	propazine (1)
Sugar beet	(4.5) (3.5) CDEC (3) TCA (4) endothal + propham, 2,3-dichloroallyl di-isopropylthiolcarbamate (3)
Red beet	endothal(6)+propham (4.5)
Mangolds	endothal(4)+propham(3)
Kale	EPTC (2) CDEC (8) CDAA (8)
Turnips	CDEC (8) CDAA (8)
Swedes	CDEC (8) CDAA (2)

* figures in brackets indicate the maximum dose applied or the maximum dose which did not cause damage, in lb/ac.

In the trials so far carried out, the degree of weed control has, in general, been little affected by incorporation of the herbicide when compared with its application to the soil surface. The principle exceptions have been: 1) the volatile herbicide EPTC which has given consistently better results both at Sprowston and Begbroke when incorporated and 2) propazine which has resulted in better control of *Matricaria chamomilla* at Begbroke when applied to the surface. In common with recent American experience it has been found that under some conditions, e.g in a stale seed-bed, the rotary cultivator alone without any herbicide treatment can give almost complete weed control. An extensive programme of testing is now required to evaluate the efficiency of this technique as a method of weed control, covering different soils, weeds, herbicides and weather.

DISCUSSION

S.I.D. is the result of an attempt to introduce some precision into the treatment of drilled row-crops with soil-acting herbicides by eliminating some of the variable factors which can affect the results. The potential usefulness of the technique described does however depend upon the availability of herbicides that are of inherently low toxicity to the crop in question. In this respect, the preliminary results obtained so far with a range of crops and herbicides are promising, but will require confirmation in further work.

The advantage in terms of improved weed control cannot be assessed until much more experience has been obtained. Before the technique can justify commercial development, it must be demonstrated that the advantages in terms of

increased efficiency outweigh the cost in comparison with cheaper conventional methods.

The solution of the problem is at present made more difficult by the lack of information on the performance of the rotary cultivator as a method for incorporating chemicals with the soil and on the maximum depth from which the seedlings of different weeds can emerge. Except for such large seeded weeds as wild oats, which are able to emerge from a depth of 4 in. or more, it can perhaps be assumed that annual weeds are only likely to become a problem in a particular crop, if their seeds are present in the top 2 in. of soil. If so, then S.I.D., to be efficient, must be able to mix the herbicide uniformly with the soil to a depth of 2 in., and provide deeper incorporation if required. As yet, however, no information has been obtained concerning the distribution of a herbicide in the soil following incorporation by S.I.D. at various depths of cultivation and in different soils. Until this information is available and the dose of herbicide can be referred to as the concentration throughout a given depth of soil in terms, for example, of parts per million of air-dry soil, biological results obtained with the machine will be of limited value. Needless to say, calibration of S.I.D. as a method of incorporating herbicides stands at the head of the list of work waiting to be done.

Acknowledgements

The authors wish to acknowledge the help given by F. Rayns of The Norfolk Agricultural Station, Sprowston and The Sugar Beet Growers Association who took an active interest in this project from the start and shared the costs. They wish also to thank for their willing co-operation: H. J. Hamblin, G. R. Chalmers and D. K. Kemp of the National Institute of Agricultural Engineering who designed and built the machine, A. F. Murant and G. W. Cussans who carried out the field testing at Sprowston and J. Holroyd and G. W. Ivens who took part in the trial work at Begbroke.

Discussion on preceding two papers.

Dr. F. Valenza. Can Mr. Bagnall's machine be used for drilling rubbed and natural seed and has the machine been tested and proved successful on all types of soil?

Mr. B. H. Bagnall The precision machine is basically designed for rubbed and graded seed; with natural seed there is some difficulty in getting a thin regular stand and one would have to go over to a heavier seeding rate. We carried out trials on stony soils and found difficulty in getting a regular spray pattern if stones covered the soil. There was no difficulty in getting good results from normal heavy, medium and light soils.

RECENT DEVELOPMENTS IN GRANULAR HERBICIDES IN THE UNITED STATES

G. F. Warren

Purdue University, Lafayette, Indiana, U.S.A.

Summary: The use of granular herbicides has expanded rapidly in the United States during the past few years. The popularity of granular materials is due especially to convenience, but also to other factors such as broadening selectivity on established or transplanted crops and obtaining better penetration of foliage. There are several problems and limitations in the use of granular herbicides. Among these are the higher cost which must be offset by savings in labour or other advantages. The lack of suitable equipment for application is a serious problem but progress is being made in this area. Results are not always as good as when sprays are used. Possible reasons for this and corrective measures are discussed.

INTRODUCTION

The use of granular herbicides in the United States has expanded rapidly in the past few years and granular formulations of practically all soil active herbicides are now available. For some crops, pre-emergence herbicides are applied to more acres as granular materials than as sprays. The factors that have brought about this rapid change and the problems involved in the use of granular herbicides will be the subjects discussed in this paper.

HISTORICAL

The early experimental work with granular formulations was instigated in an attempt to broaden selectivity on certain vegetable crops. They were applied to transplanted or established plants to avoid the direct contact injury that might occur to the foliage from sprays of the same materials (Danielson, 1954 and 1955 and Warren *et al.* 1947). This technique, which has now been widely investigated and extended to other crops, is used commercially in many areas. It has been an important milestone in expanding the use of herbicides in horticultural and certain field crops. In the past four years a tremendous increase in the use of granular materials on maize and soya beans at time of seeding has tended to over-shadow the original work. This, and some other uses, have come about mainly because granular materials are more convenient to use for these purposes than are sprays.

Before going further, we should briefly describe what we mean when we speak of granular formulations. The term has been used to describe a variety of materials but in all cases the chemical is adsorbed on, mixed with, or impregnated into a more or less inert carrier. The final product is dry, and it must flow freely through various spreaders. In the early experiments vermiculite was often used as a carrier, but because of excessive bulk and problems of drift on windy days, the main carriers now in use are various types of clay. The final product consists of granular particles somewhat smaller than white clover seed. Some of the herbicides that are being marketed in granular formulations

are: 2,4-D, dinoseb, CDAA, chlorpropham (CIPC), EPTC, NPA, fenuron, simazine and atrazine.

ADVANTAGES CLAIMED FOR GRANULAR HERBICIDES

Let us now look at some of the factors which appear to have brought about the rapid expansion in the use of granular herbicides.

1. Convenience. The ease and simplicity of applying granular materials has been a major factor in farmer acceptance. Maize, soya-beans or other seeded crops may be band-treated at time of planting by adding a herbicide hopper behind the planter. This means that no extra operation is needed and it requires less equipment and labour than mounting a sprayer in the same way. There is no water to haul and there are no spray nozzles to block. In the case of herbicides like propham and EPTC, that are sometimes applied broadcast and worked in before planting, a granular product can be mixed with the fertilizer and an entire operation saved.

The householder has been another beneficiary of the development of granular herbicides. (Daniel, 1958). For pre-emergence control of annual grasses such as *Digitaria* species in turf, granular formulations of arsenic, chlordance and other compounds are taking over the market. It is much simpler for the home user to spread a dilute granular herbicide uniformly on his lawn with a small fertilizer spreader than to apply the same chemical as a spray.

Other places where granular materials are more convenient than sprays are for the treatment of small patches of perennial weeds and individual trees or shrubs with soil sterilants. They are also valuable for brush control in rough terrain where the transportation of water is difficult. The effectiveness of such treatments for control of trees was first reported by McCully and Darrow (1956).

2. Avoid direct injury to the foliage of established or transplanted crops. As pointed out earlier, this was the feature of granular herbicides that prompted the early work. There are many herbicides which cause some damage to the foliage of crops when applied as a spray, but are tolerated by the crop roots or do not move deeply enough in the soil to be absorbed by the roots. Several cases of increasing the selectivity of a herbicide by this means have been reported (Chapell and Bower, 1959; Shear, 1959; Warren, 1957).

3. Less vapour loss of certain herbicides. Observations by several research workers have indicated that volatile chemicals such as propham, chlorpropham and especially EPTC are more effective when applied in granular formulations than as sprays. This has often been attributed to less loss as vapours. Although this may be an advantage for granular materials, the decrease in vapour loss is not sufficient to eliminate the need for soil incorporation of EPTC.

4. Better penetration of foliage. Better results with granular applications, as compared with sprays, of two herbicides applied after the last cultivation on sweet potatoes were attributed to penetration of the foliage and greater concentration of herbicide on the soil surface (Danielson, 1956). This is considered to be an important feature in the extensive treatment of alfalfa (lucerne) with granular chlorpropham for control of dodder (*Cuscuta* spp.). It has also been pointed out that, for soil-active chemicals, granular applications may be the only practical way to treat brush to avoid interception by the foliage.

5. Less damage from equipment with applications in growing crops. This has been an important feature in the swing towards greater use of granular herbicides in onions. CDAAs and chlorpropham are commonly applied as directed sprays to control late season weeds, but because of the narrow row spacing there is considerable damage to the onions from the spray equipment. Granular materials are applied above the foliage, whereas sprays are applied behind height-adjustment wheels between the rows.

6. Better control of rooted aquatic weeds. Granular applications are a convenient and effective way of getting soil active herbicides to the bottom of lakes and ponds for the control of rooted aquatic weeds.

There are other advantages that are sometimes claimed for granular herbicides, but certainly those listed above are some of the most important.

DISADVANTAGES OF GRANULAR HERBICIDES

To leave the impression that there are no problems in connection with the use of granular materials would be a serious error. There are many factors which will limit their use even if some of the problems are solved. Some of the disadvantages of granular herbicides are higher cost, lack of suitable equipment for application and erratic results. These will be discussed in detail.

1. Higher cost. The cost of material is higher when using granular herbicides because of the additional expense for carrier and freight. Any use must therefore be based on other factors compensating for the extra cost of material. The rapid acceptance by farmers would indicate that they believe that the added expense is more than offset by the saving in labour in application or by other advantages as discussed earlier.

2. Lack of suitable equipment for application. This has been a real disadvantage. Improvements are being made but most present-day equipment is far from ideal. However, there is every reason to believe that this disadvantage will be overcome in time.

3. Erratic results. In several experiments weed control has been as good or better with granular treatments as with sprays (Danielson, 1955, 1956; Sweet et al. 1958; Lovely and Staniforth, 1959). On the other hand, there have been numerous cases where granulars were inferior to sprays. Some of the possible reasons for these inconsistent results will be discussed briefly.

There are indications that more soil moisture is needed for effective weed control with granulars than with sprays. Sprinkler irrigation or soil incorporation following treatment are the only methods suggested to alleviate this problem. Experimental data on the value of these practices is much too limited at present to draw any definite conclusions, but more research is under way.

Some of the poor results obtained may have been due to applications on rough, cloddy ground where the distribution pattern on the surface is poor. This is probably more serious for the less soluble herbicides. In any case, good seedbed preparation would be desirable.

In general, there have been more failures with granular formulations of the less soluble materials. This might be partly overcome by using a more dilute product to obtain better coverage of the soil surface. Lovely and Staniforth (1959) found that 8 per cent simazine was not as effective as a 4 per cent simazine granular material. On the other hand, the use of more dilute granular formulations did not influence the results with the more soluble CDAA or 2,4-D-ester.

Considerable attention has been focused on the carriers used in formulating granular materials but results in the field do not indicate that this is an important factor as long as the formulated granules have suitable physical properties for application.

One final point that should be emphasized is the lack of contact action of granular herbicides. With the exception of a few chemicals with vapour activity, all the effect of a granular treatment must come through root absorption. For selective use, it is essential to apply granular herbicides immediately after planting, on freshly worked soil, or after removal of all weeds by tillage in an established crop.

Acknowledgments.

The author is grateful for much unpublished information used in preparing this paper which was kindly supplied by the following United States workers: L. L. Danielson, W. R. Furtick, G. R. Ferguson, H. H. Harris, D. D. Hemphill, O. C. Lee, W. C. McConnell, F. W. Slife, R. D. Sweet and W. Weber.

REFERENCES

- CHAPELL, W. E. and BOWER, F. L. (1959). Granular and Spray Applications of Certain Herbicides in Strawberries and Raspberries. Proc. Northeastern Weed Control Conf. 13, 64-68.
- DANIEL, W. H. (1958). Preventing Crabgrass in Turf Areas. Proc. North Central Weed Control Conf. 15, 35-36.
- DANIELSON, L. L. (1954). Experimental Use of Herbicides Impregnated on Clay Granules for Control of Weeds in Certain Vegetable Crops. Proc. Northeastern Weed Control Conf. 8, 119-126.
- DANIELSON, L. L. (1955). Comparison of Granular and Spray Applications of Herbicides in Vegetable Crops. Proc. Northeastern Weed Control Conf. 9, 89-95.
- DANIELSON, L. L. (1956). Effect of Granular Herbicides on Yields of Tomatoes and Sweet Potatoes. Proc. Northeastern Weed Control Conf. 10, 116-121.
- LOVELY, W. G. and STANIFORTH, D. W. (1959). Granular Herbicide Formulations for Weed Control in Corn. Proc. North Central Weed Control Conf. 16, 54-54.

REFERENCES (Contd.)

- MCCULLY, W. G. and DARROW, R. A. (1956). Aerial and Broadcast Applications of Granular Karmex in Oak Woodlands. Proc. Southern Weed Conf. 9, 118-120.
- SHEAR, G. M. (1959). Some Effects of CIPC on Chickweed and Alfalfa. Southern Weed Conf. 13, 33-35.
- SWEET, R. D., CRABTREE, G. and BAKES, D. (1958). A Comparison of Granular and Liquid Carriers for Herbicides. Proc. Northeastern Weed Control Conf. 12, 25-32.
- WARREN, G. F., BUCHHOLTZ, K. P., and HERNANDEZ, T. P. (1947). Preliminary Studies on the Effects of Soil Applications of 2,4-D on Crop and Weed Growth. Proc Amer Soc Hort Sci. 50, 373-382.
- WARREN, G. F. (1957). Studies on the Control of Weeds in Transplanted Tomatoes. Proc. North Central Weed Control Conf. 14, 46.

Discussion on preceding paper

Mr. A. L. Abel. Would Professor Warren please indicate whether the granules referred to are of uniform composition all through or are they coatings of the active ingredient on an inert filler?

Dr. G. F. Warren. Some granules were based on vermiculite but we then switched to attapclays because vermiculite may blow into the neighbour's field and the bulk is quite excessive. Last year we had a series of granules from one company with the material in the granule or on the surface. They were applied at equal rates of active ingredient and the results were all the same. Other research workers also have reported little or no difference in weed control or crop injury when various types of granules were used. One must conclude that factors other than formulation are more important in determining the results in the field.

SESSION XI

Chairman: Dr. E. E. Cheesman

THE TRANSLOCATION OF HERBICIDES IN PLANTS

THE TRANSLOCATION OF HERBICIDES IN PLANTS

Dr. C. C. McCready

Agricultural Research Council Unit of Experimental
Agronomy, Department of Agriculture, University of Oxford.

INTRODUCTION

When herbicides are applied to plants, they do not simply diffuse according to laws of their own. They are translocated almost entirely in transport systems already functioning in the plants. The aim of this lecture is to consider how far what is known about the movements of herbicides in plants fits in with what is known about the natural translocation mechanisms. No attempt will be made to survey comprehensively the extensive literature on the translocation of herbicides. Reference may be made to reviews by van Overbeek (1956), Woodford, Holly and McCready (1958), Bollard (1960) and Zimmertann (1960), and to the valuable annotated bibliography by Hull (1960).

METHODS

All investigations of the translocation of herbicides depend on methods for determining the distribution of the herbicide in the treated plant, and the difficulties in such determinations have been discussed by Woodford, Holly and McCready (1958). In particular, attention may be directed to the necessity for caution in interpreting autoradiographs of plants treated with radioactive herbicides. The distribution of radioactivity in the plant shows only the distribution of the labelled element and not necessarily that of the molecule in which it was originally incorporated.

It is difficult in practice to distinguish between absorption and translocation, and the distribution of herbicides in plants can be much affected by factors which may be presumed to alter absorption rather than translocation (Leasure 1960, Shiue, Hossfeld and Rees, 1958).

Movement in the xylem. Criteria of movement in the xylem include:

- 1) Movement occurs upward from the roots (although not all upward movement is in the xylem)
- 2) Movement is stopped by severing the xylem
- 3) Movement is unaffected by ringing the stem

- 4) Movement continues through a zone killed by local heating
- 5) Movement is altered by factors affecting the rate of transpiration

Herbicides which have been shown to move up the plant in the transpiration stream include 2,4-dichlorophenoxyacetic acid, trichloroacetic acid, ammonium sulphamate, monuron, amino triazole, prophan, simazine and maleic hydrazide. Probably any substances which can enter through the roots can move up the xylem, but Crafts and Yamaguchi (1960) have shown considerable differences in the extent to which different herbicides applied in culture solution to barley seedlings were retained in the roots: 2,4-D moved into the top less readily than amino triazole, maleic hydrazide, monuron, dalapon or simazin. Blackman and co-workers (Blackman 1960) found that the time course of uptake of 2,4-D by the roots of seedlings of different species shows differences which may be correlated with the susceptibility of the species to 2,4-D. In these experiments, however, translocation into the shoot did not correlate with susceptibility. Crafts (1959) reported that monuron applied to a small area half way along a barley leaf moved only towards the tip. He interpreted this as showing movement with the transpiration stream not in the xylem but in the apoplast or non-living part of the tissue (cell-walls and intercellular spaces).

Movement in the phloem. Criteria of movement in the phloem include:

- 1) Movement occurs in the (presumed) direction of movement of the carbohydrate stream
- 2) Movement does not pass a girdled region of the stem
- 3) Movement does not pass through a zone killed by local heating
- 4) Movement is altered by factors affecting the rate of carbohydrate movement.

It was early shown that the export of 2,4-D from leaves to which it was applied was closely related to the export of carbohydrate, and more recently the concept of the assimilating stream as the controlling influence in the export of herbicides after foliar application has been extensively developed by Crafts and his school (e.g. Crafts and Yamaguchi 1958; Yamaguchi and Crafts 1959; Crafts 1959).

Circulation in the plant Crafts has also suggested that the mere mobile herbicides (e.g. maleic hydrazide), after moving in the phloem from leaves to roots, may be transferred to the xylem and return with the transpiration stream to the leaves. Inorganic phosphorus has been shown to circulate in this way in plants, and sugars may occasionally do so.

Polar Transport. Some phenoxyacetic acids have been shown experimentally to move through excised segments of tissue by a mechanism resembling the polar transport of natural auxin. This mechanism is highly selective between different closely related chemicals. Some recent evidence suggests that a mechanism similar in some ways may be involved in the movement of 2,4-D from the surface of the leaf into the vascular tissue in which phloem movement occurs.

CONCLUSION

Although existing knowledge of translocation systems in the plant accounts fairly satisfactorily for the different modes of movement of herbicides, nothing is known of the reasons why different chemicals move in different ways.

There is some evidence that differences between the movement of certain herbicides in different species may occasionally be related to differences in susceptibility, but no generalisations are yet warranted.

BIBLIOGRAPHY

- BLACKMAN, G. E. (in press) In: Proceedings of the International Conference on Plant Growth Substances, New York, 1959.
- BOLLARD, E. G. (1960) Transport in the xylem. *Ann. Rev. Plant Physiol.* 11, 141-166.
- CRAFTS, A. S. (1959) Further studies on comparative mobility of labelled herbicides. *Plant Physiol.* 34, 613-620.
- CRAFTS, A. S. and YAMAGUCHI, S. (1958) Comparative tests on the uptake and distribution of labelled herbicides by *Zabrota pendula* and *Tradescantia fluminensis*. *Hilgardia* 27(16): 421-454.
- CRAFTS, A. S. and YAMAGUCHI, S. (1960) Absorption of herbicides by roots. *Amer. J. Bot.* 47, 248-255.
- HULL, H. M. (1960) A tabular summary of research dealing with translocation of foliar-applied herbicides and selected growth regulators. *Weeds* 8, 214-231.
- LEASURE, J. K. (in press) The effects of added penetrant aids and wetting agents on the response of quack-grass (*Agropyron repens* (L.) Beauv.) to dalapon. *Proc. Fifth British Weed Control Conf.*, 1960.
- SHIUE, C. J., HOSSFELD, R. L. and REES, L. W. (1958) Absorption and translocation of 2,4,5-trichlorophenoxyacetic acid derivatives in quaking aspen. *Forest Sci.* 4, 319-324.
- VAN OVERBEEK, J. (1956) Absorption and translocation of plant regulators. *Ann. Rev. Plant Physiol.* 7, 355-372.
- WOODFORD, E. K., HOLLY, K., and McCREADY, C. C. (1958) Herbicides. *Ann. Rev. Plant Physiol.* 9, 311-358.
- YAMAGUCHI, S. and CRAFTS, A. S. (1959) Comparative studies with labelled herbicides on woody plants. *Hilgardia* 29(4): 171-204.
- ZIMMERMANN, M. H. (1960) Transport in the phloem. *Ann. Rev. Plant Physiol.* 11, 167-190.

Discussion on preceeding paper

Mr. R. W. Sidwell

The translocation of herbicides in the phloem and xylem presents no problems once the materials have entered these tissues. If the movement of materials through the mesophyll into the phloem is polar movement as Dr. McCready suggests, how does he account for the apparent fact that in the translocation of materials upwards, young unexpanded leaves can receive these substances from the phloem terminals? Can we assume an 'anti-polar' movement?

Dr. C. C. McCready

The answer is that there is no evidence.

SESSION XII

Chairman: Mr. M. N. Gladstone

BUSINESS MEETING

MINUTES OF THE CONFERENCE BUSINESS MEETING HELD AT 3.15 P.M. ON
THURSDAY, 10TH NOVEMBER, 1960 AT THE GRAND HOTEL, BRIGHTON

Present: Dr. H. G. Sanders (President)
Mr. M. N. Gladstone (Chairman)
Mr. H. S. Leech (Treasurer)
Miss C. Bloemink (Secretary)

together with about 50 members of the Conference.

1. MINUTES OF THE BUSINESS MEETING OF THE 1958 CONFERENCE

The Minutes of the meeting held at Brighton on 6th November, 1958, having been circulated to each Conference member, were taken as read and agreed.

2. ELECTION OF PRESIDENT

Mr. Gladstone announced that, in accordance with the Constitution, Professor Sanders automatically retired as President of the Council after the Conference. On behalf of the Council, Mr. Gladstone thanked Professor Sanders for his valuable services during the two years of his office and paid a special tribute to the exceptional energy and help he had given to the 1960 Conference. Mr. Gladstone then asked for nominations for the office of President for the period of two years until the next Conference. Mr. Billitt proposed Professor Sanders for this office and Mr. Huckle seconded the proposal. As there were no other nominations and Professor Sanders expressed his willingness to serve, Mr. Gladstone declared him President for a further period of two years and the proposal was carried with acclamation. Professor Sanders said he was very pleased to accept the office and that he was deeply sensible of the honour.

3. SECRETARY'S REPORT

Mr. Gladstone referred to the Secretary's Report (appended) covering the activities of the Council since November 1958, which has been circulated to all members, and asked for comments. He said that he had been notified by Mr. Ferro that the penultimate paragraph on page 8 of the Report under the heading "Use of Sodium Arsenite" was incorrect. Mr. Ferro asked that this paragraph should be deleted and he suggested a revised phrasing. After some discussion, it was agreed that the paragraph in question should be replaced by the following:

"Discussions between the Government and Industry resulted in December 1959 in an agreement that manufacture should stop forthwith and that stocks could be used for the 1960 potato harvest after which there would be no further use of the material as a herbicide or potato haulm killer."

With this correction, Mr. Baldit moved the adoption of the Report; the proposal was seconded by Mr. Hartt and carried.

4. FUTURE ACTIVITIES OF THE COUNCIL

Mr. Gladstone, referring particularly to the Conference which had just ended, invited Conference members to forward written comments or criticisms to the Council. He said that any suggestions for improving the running and organisation of the next and future Conferences would be very welcome.

5. ANY OTHER BUSINESS

The Secretary reported that no further items had been submitted for discussion at the business meeting, in accordance with Item 13(d) of the Constitution.

6. CLOSING OF THE CONFERENCE

Professor Sanders said that the general opinion appeared to be that the Conference had been very successful. In bringing the Conference to a close he drew attention to what he considered had been the highlights of the Conference:

(a) The progress made in the development of residual herbicides. He felt that this was a very important subject and much more would be heard about it in the future in view of the problems in connection with residues.

(b) A great deal had been said about the use of herbicides in grassland, and there had been new slants on this subject, particularly the idea of herbicides being selective among grasses. Professor Sanders said he thought there was a very great future for selective herbicides for this purpose. He drew attention, however, to the need for appropriate crop husbandry after chemical treatment.

(c) The papers concerned with the control of couch grass and wild oats had been very stimulating, but it would be some time before a full answer to these problems would be available.

(d) Referring to the session on Weed Control in Horticultural Crops, Professor Sanders said he agreed with the Session Chairman that more attention should be paid to the development of herbicides for the market garden. He regarded this field as a very pressing one in view of the increase in the cost of and scarcity of labour.

(e) On the subject of New Herbicides and Techniques, Professor Sanders remarked on the great developments in these fields, and he stressed the need for the closest co-operation with the machinery manufacturers.

Finally, Professor Sanders expressed his thanks to all those who had helped to make the Conference a success. He paid a special tribute to the management and staff of the Grand Hotel and to the Conference Organisers, in particular, Mr. Bishop, Mr. Parker, Mr. Leech and Mr. Morris, and expressed appreciation of all the work put in by Col. Cramphorn, Chairman of the Conference Organising Committee who was unfortunately unable to be present owing to an accident. Professor Sanders also expressed grateful thanks to the Chairmen of the respective Sessions, the Session Organizers, the speakers and all who had taken part in the discussions for their valuable contributions.

SECRETARY'S REPORT ON THE ACTIVITIES OF THE COUNCIL SINCE THE
BRITISH WEED CONTROL CONFERENCE, 1958

MEMBERSHIP OF THE COUNCIL

Changes in membership of the Council that have occurred are as follows:

Mr. G. L. Baldit has replaced Dr. F. P. Coyne as representative of the Society of Chemical Industry, Mr. J. Rhodes has replaced Mr. A. D. Harrison as representative of the Ministry of Agriculture, Fisheries and Food and Mr. D. W. Robinson has replaced Professor J. Morrison as representative of the Ministry of Agriculture for Northern Ireland. Col. J. F. Cramphorn (N.A.C.A.M.) and Mr. W. F. P. Bishop (N.A.A.C.) were co-opted as members of the Council for the period to 31st December, 1960 in their respective capacities of Chairman and Secretary of the 1960 Conference Organising Committee. Dr. E. Holmes retired as Chairman of the Council and Mr. M. N. Gladstone was elected in his place. Mr. H. S. Leech was re-elected as Treasurer of the Council. Miss C. Bloemink has undertaken secretarial duties for the Council. Mr. W. A. Williams, Secretary of A.B.M.A.C., has attended meetings of the Council during the past two years. The full membership of the Council is therefore now as follows:

President

Dr. H. G. Sanders, M.A., Ph.D.

Chairman

Mr. M. N. Gladstone A.B.M.A.C.

Treasurer

Mr. H. S. Leech N.A.C.A.M.

Members

Dr. R. de B. Ashworth	M.A.F.F.	
Mr. G. L. Baldit	S.C.I.	
Mr. A. W. Billitt	A.B.M.A.C.	
Mr. W. F. P. Bishop	N.A.A.C.	(co-opted)
Mr. M. Bradford	N.A.C.A.M.	
Dr. E. E. Cheesman	A.R.C.	
Col. J. F. Cramphorn	N.A.C.A.M.	(co-opted)
Mr. C. V. Dadd	M.A.F.F.	
Mr. S. A. Evans	M.A.F.F.	(co-opted)
Mr. R. B. Ferro	M.A.F.F.	(co-opted)
Mr. D. J. S. Hartt	A.B.M.A.C.	
Mr. R. G. Heddle	Dept. of Ag. for Scotland	
Dr. E. Holmes	A.B.M.A.C.	
Mr. D. J. Columbus Jones	M.A.F.F.	
Mr. R. E. Longmate	N.A.A.C.	
Mr. H. C. Mason	N.F.U.	
Mr. F. W. Morris	N.A.A.C.	
Mr. D. Rhind	Colonial Office	
Mr. J. Rhodes	M.A.F.F.	

Members (contd.)

Mr. D. W. Robinson	Min. of Ag. for Northern Ireland
Dr. R. E. Slade	N.F.U.
Mr. W. A. Williams	
Dr. E. K. Woodford	A.R.C. and A.A.B.

Secretary

Miss C. Bloemink

Full meetings of the Council have been held quarterly and, in addition, the various Committees of the Council appointed to deal with special aspects of the Council's work, have met at intervals during the past two years. Membership of these Committees are as follows:

Research & Development Committee

Mr. R. B. Ferro	(Chairman)	Mr. R. E. Longmate
Mr. S. A. Evans	(Secretary)	Mr. J. S. W. Simonds
Dr. R. de B. Ashworth		Dr. R. E. Slade
Mr. C. V. Dadd		Dr. E. K. Woodford
Mr. M. N. Gladstone		

Recommendations Committee

Dr. E. K. Woodford	(Chairman)	Mr. J. D. Fryer
Mr. S. A. Evans	(Secretary)	Dr. K. Holly
Dr. H. P. Allen		Mr. G. D. Holmes
Dr. R. de B. Ashworth		Mr. D. J. C. Jones
Mr. M. Bradford		Mr. R. E. Longmate
Mr. G. W. G. Briggs		Mr. G. B. Lush
Mr. K. Carpenter		Mr. J. Rhodes
Mr. C. J. Edwards		Mr. H. A. Roberts
		Mr. F. R. Stovell

Publications Committee

Mr. A. W. Billitt	(Chairman)	Mr. F. W. Morris
Mr. H. S. Leech	(Secretary)	Dr. E. K. Woodford

1960 Conference Organising Committee

Col. J. F. Cramphorn	(Chairman)	Mr. D. J. S. Hartt
Mr. W. F. P. Bishop	(Secretary)	Mr. H. S. Leech
Mr. A. W. Billitt		Mr. H. C. Mason
Mr. C. V. Dadd		Mr. F. W. Morris
Mr. M. N. Gladstone		Dr. E. K. Woodford

Finance Committee

Mr. F. W. Morris	(Chairman)	Mr. M. Bradford
Mr. H. S. Leech	(Secretary)	Mr. H. C. Mason

CONFERENCES, SYMPOSIA AND TECHNICAL MEETINGS

B.W.C.C. Symposium Fund. As it was recognised that some of the more specialised aspects of weed control could not be dealt with at the biennial Conference, it was agreed that the Council should hold Symposia as and when the occasion arose to deal with these special subjects. It was considered desirable therefore to set up a fund to assist towards the expenses involved in publishing the Proceedings of such Symposia. An appeal was therefore made to industry for financial support. The response was most encouraging and the Symposium Fund now stands at £749-13-7. The Council records its appreciation of the voluntary financial assistance given.

N.A.A.S. Conference, South Western Region. A farmers' Weed Control Conference was held on 25th February, 1959 at Salisbury and approximately 200 people attended from Dorset, Hampshire and Wiltshire. The following subjects were dealt with:

1. Weed Control in Cereals
2. Mechanical and chemical control of Couch Grass
3. Chemical Weed Control in Herbage Seed Production
4. Weed Control in Kale

The Conference was a success and the discussions lively. In particular, the grass session was a most valuable one.

European Agricultural Aviation Conference. The European Agricultural Aviation Conference organised jointly by the European Agricultural Aviation Centre (sponsoring body), the Association of British Manufacturers of Agricultural Chemicals, the Colonial Office, the Fertilizer Manufacturers' Association, the Ministry of Agriculture, Fisheries and Food, the Ministry of Transport and Civil Aviation, the National Association of Agricultural Contractors, the National Association of Corn and Agricultural Merchants, the Royal Aeronautical Society and the Society of Chemical Industry, took place at Cranfield from 14th to 17th September, 1959 with a flying demonstration, organised by the N.A.C.C., on 18th September, 1959. The outline programme was as follows:-

- 1st Day - Agricultural Chemicals and Fertilizers including their biological efficiency
- 2nd Day - Aircraft, equipment and corrosion problems
- 3rd Day - Economics and Flying

250 delegates attended the Conference, 80 from abroad, 25 countries being represented. The Conference was judged to be a success and provided a useful opportunity for the exchange of views on the subject of agricultural aviation.

Symposium on Herbicides and the Soil. A symposium on Herbicides and the Soil, sponsored by the British Weed Control Council, was held on 7th April, 1960 at Oxford. The following papers were presented:

1. Microbiological Breakdown of Herbicides in Soils
2. The Effects of Herbicides on Soil Micro-organisms
3. Physico-chemical aspects of the availability of Herbicides in Soils
4. Persistence in the Soil of some important Herbicides.

176 persons attended the Symposium which was very successful. Proceedings are being published.

International Research Group on Weed Control European Weed Research Council.

An International Research Group on Weed Control was set up at Ghent on 5th May, 1958 with the idea of fostering international collaboration on problems connected with weed research. The first conference of the Group was held in Stuttgart on 3rd and 4th March, 1959 on "Aspects of Weed Control", the subjects discussed being:

1. Weed Control in Forestry
2. Wild Oat Control
3. Weed Control in Vegetable Crops
4. Herbicides and the Soil

At this meeting an interim Council was set up to consider (a) the formation of a European Weed Society and (b) the publication of a European Weed Journal.

The next meeting of the Group took place in Oxford on 5th and 6th April, 1960 and 60 visitors from overseas attended. The following subjects were discussed:

1. Control of Couch Grass
2. Control of Water Plants
3. Control of other Perennial Grasses
4. Control of Bracken
5. Control of Wild Oats
6. Weed Control in Vineyards
7. Herbage Seed Crops

At the business meeting, the future of the Group was discussed and it was decided to form a European Weed Research Council. Dr. E. K. Woodford, a member of the British Weed Control Council, had attended all the meetings of the Group and represented British interests. The British Weed Control Council agreed to be associated with the activities of the European Weed Research Council and, at their meeting on 9th June, 1960, recommended that Dr. Woodford should be nominated as the permanent U.K. representative on the European Council and that he should report its activities to the British Weed Control Council. Dr. Woodford was authorised, when he was unable to attend meetings of the European Council, to appoint a deputy who could report to the British Weed Control Council either directly or through himself. The European Weed Research Council also decided to publish a new journal to be called "Weed Research".

1960 Weed Control Conference. The British Weed Control Council had agreed that the holding of a Conference every two years was most appropriate and that the fifth Conference should therefore take place from 7th to 10th November, 1960, the venue being the Grand Hotel, Brighton. The Council had also decided that they would organise and run their own Conference, and a Conference Organising Committee was set up which has taken on the overall responsibility for this work.

Proposed one-day Conference on Industrial Weed Control. It is hoped to arrange a Conference on the subject of Industrial Weed Control shortly.

PUBLICATIONS

Weed Control Handbook, 1958 (1st edition). A new edition of the Handbook was published in November, 1958 by Blackwell Scientific Publications Ltd., Oxford. This was in a more comprehensive form than previous editions and was sold at 12/6d a copy. 7,500 copies were printed of which approximately 6,200 have been sold. This edition continued to be sold until the end of September, 1960.

Weed Control Handbook, 1960 (2nd edition). The Recommendations Committee of the British Weed Control Council have been working on a second edition of the Weed Control Handbook. This will again be printed and published by Blackwell Scientific Publications Ltd. and will be on sale in November, 1960. This second edition will be in the same format as the first edition and will cost 17/6d a copy. 6,000 copies will be printed.

Proceedings, 4th British Weed Control Conference, 1958. The Proceedings of the 4th British Weed Control Conference held at Brighton in November, 1958 were edited and published by the Society of Chemical Industry in February, 1960. Delegates to the Conference each received a copy. Copies are available from the Society of Chemical Industry at a cost of £2-10/- each.

Report of the Recommendations Committee, 1959. This Report was published in March, 1960 as a supplement to the 1958 edition of the Weed Control Handbook and included recent developments in the use of herbicides and the results of current research work. Its purpose was to tide over the gap until the next edition of the Handbook was published. Circulation of the Report was limited to those organisations represented on the British Weed Control Council.

Proceedings of Symposium on Herbicides and the Soil. Blackwell Scientific Publications Ltd. are printing and publishing these Proceedings and it is hoped that they will be available for sale in November, 1960.

Weed Abstracts. There has been an increasing demand for "Weed Abstracts" issued monthly by the Agricultural Research Council Weed Research Organisation and distributed partly through the British Weed Control Council. The annual subscription remains at £2-2-0.

Weed Research. "Weed Research", the new journal of the European Weed Research Council, is to be published in Britain by Blackwell Scientific Publications Ltd., Oxford and it is hoped that the first issue will be available in January, 1961. A guarantee fund, to which the British Weed Control Council has contributed to the extent of £100, has been set up to finance the journal.

GENERAL

Herbicide Usage. A pilot survey on Herbicide Usage on 83 farms in north-west Oxfordshire was undertaken in January and February, 1959 by the Agricultural Research Council Unit of Experimental Agronomy with the co-operation of Rothamsted and a report of the survey was presented to the British Weed Control Council. This survey gave an indication of the types and quantities of weed-killers used on the various farms and also gave some information on the type and intensity of weed infestations. It was generally agreed however that the number of farms inspected was too small and too localised to draw any broad conclusions. The survey was valuable however in deciding how a fuller scale survey could be carried out and had also shown the type of information that could be obtained.

It was thought desirable therefore that a wider survey in five or six other areas should be carried out and the N.A.A.S. have agreed to do this further work. It had not been possible to do the survey during 1959/60 but preparations are being made to carry out this work during 1960/61. A paper on the pilot survey has been published.

Labelling of Weedkillers. Following strong representations from members of the N.F.U., the British Weed Control Council passed the following resolution, which was carried by twelve votes to three (the manufacturers opposing the vote):

"This Council recommends that all weedkiller labels should bear the chemical name or the agreed common name of the active ingredient or ingredients and asks its President to bring the matter to the attention of the Ministry of Agriculture requesting them to find means of implementing this."

The Ministry were accordingly approached to introduce legislation with regard to the labelling of weedkillers. The matter was given considerable thought at the Ministry but it was considered that it would be difficult to introduce compulsory measures. The attitude of the Ministry appeared to be that the situation would probably be dealt with when the new Approval Scheme under discussion with the industry was formulated.

Spray Drift. Both the Council and the Ministry of Agriculture have issued press notices warning of the danger of spray drift. An investigation was made by the Ministry, with the assistance of other bodies, into the extent and causes of spray drift damage and methods of reducing it and a special worker was appointed by the Ministry to work under Professor Hudson of Nottingham University on the problem. A departmental committee was also set up within the Ministry of Agriculture (Lord Waldegrave's Committee) to assess the evidence submitted by various interested organisations on the damage caused by spray drift. The Research & Development Committee of the Council arranged a meeting of research workers on 16th March, 1959 at Oxford at which the various people present summarised the research they had done so far on the subject. It was agreed that there was insufficient evidence available at that time to assess the seriousness and extent of spray damage from the use of selective weedkillers and a great deal of work was still to be done in this connection. The results of the research done by the special worker appointed by the Ministry were submitted in a report to the Ministry on September, 1959. The report dealt very largely with diagnostic means. The Research & Development Committee of the Council studied the report in detail and recommended to the Council that while it was a very valuable document, it was essentially a research paper and was not in a form suitable for publication. The Report on Spray Drift is available at the Ministry Library to anyone who may wish to consult it. The Report of Lord Waldegrave's Committee is awaited.

Toxic Chemicals in Agriculture. In view of numerous inaccurate and irresponsible statements appearing in the National Press in connection with the use of toxic chemicals in agriculture, it was suggested that the Council might take some action in counteracting such adverse publicity and it was felt that some official statement on this subject should be forthcoming from the Ministry of Agriculture when the new Approval Scheme was launched. The Association of British Manufacturers of Agricultural Chemicals are however already in close touch with the Ministry and with the responsible officials of the Press and the B.B.C. on this matter, and it has been decided to leave it to A.B.N.A.C. to take the necessary action and keep the Council informed.

Use of Sodium Arsenite. The Council had been concerned for some time about the hazards involved in the use of sodium arsenite as a potato haulm destroyer and it was felt that in spite of the more stringent recommendations for use and the precautionary notices issued through the Ministry, the Council and the manufacturers, the product was not being used in a safe manner. Moreover, reports had been received that the material was being used on other crops besides potatoes, outside the recommendations for the product made by the Ministry and the manufacturers, and the Council felt that the hazards and accidents resulting from the use of sodium arsenite might jeopardise the future for agricultural chemicals generally. The British Weed Control Council decided, therefore, that the matter should be taken further. In preference however to recommending that the use of the product should be banned, the Council agreed that manufacturers should be asked to voluntarily cease to supply the chemical to farmers, and the following resolution was passed:

"that the Council recommend the A.B.M.A.C. to advise their members to cease selling sodium arsenite as a herbicide and defoliant."

The Council further resolved:

"that the Ministry should be asked to delete sodium arsenite from its Approved List."

The Ministry subsequently asked manufacturers to agree to cease making the product after the autumn of 1960 and this was agreed. The Council are continuing, in the meantime, to enquire into the progress made in the development of alternative means of potato haulm destruction. At their meeting on 9th June, 1960, brief details were given of "diquat" a promising new compound for this purpose.

C. Bloemink
Secretary

LIST OF DELEGATES

ABEL, A. L..
Fisons Pest Control, Ltd.

ABBI, DR. HANS
CIBA Limited, Basle, Switzerland.

AELBERS, ir. E
N.V. Orgachemia,
Boseind 2, Boxtel, Holland.

ALDHOUS, J. R..
Forestry Commission Research
Station,
Farnham, Surrey.

ALLEN, DR. H. P..
Plant Protection Ltd., Fernhurst,
Nr. Haslemere, Surrey.

ALLEN, M. G..
Shell Chemical Co. Ltd.,
London, W.1.

AMBROSE, B. T..
Agricultural Spraying Co. Ltd.,
Cavendish, Suffolk.

AMEY, LEONARD
Agricultural Correspondent.
303 Cherryhinton Rd., Cambridge.

ANDERSON, E. G..
Canada Agriculture, Ottawa, Canada.

ANGELL, G. L..
CYNAMID of Great Britain, Ltd.,
Chatteris, Cambs.

ANNIS, C. W..
Lincs Aerial Spraying Co.,
Boston, Lincs.

ARNOLD, G. I..
Boots Pure Drug Co. Ltd.,
Nottingham.

ASHWORTH, BRIAN,
Disinfestation Ltd., East Grinstead.

ASPLIN, J. W..
Agricultural Contractor,
Sprotborough, Doncaster, Yorks.

BACHEM, K. E..
Baywood Chemicals Ltd.,
London, W.C.1.

BAGNALL, BRIAN H..
Murphy Chemical Co. Ltd.,
Wheathampstead, St. Albans, Herts.

BAINES, JOHN
Insurance Consultant,
17 Redcliffe Sq., London, S.W.10.

BAKER, DR. H..
Grassland Research Institute,
Hurley.

BAKKEREN, M. H. C. M..
N.V. Agrunol Chemical Works,
Groningen, Holland.

BALDIT, G. L..
Plant Protection Ltd.,
Fernhurst, Surrey.

BALL, R. W. E..
May & Baker Ltd., Ongar, Essex.

BARKER, MICHAEL
NAAS, Lincs. (Holland), Boston,
Lincs.

BARLOW, J. N..
F. W. Berk & Co. Ltd., London, W.1.

BARNESLEY, G. E..
"Shell" Research Ltd.,
Sittingbourne, Kent.

BARRETT, E. W..
Dow Agrochemicals Ltd., London, W.1.

BATES, R. J. E..
Manor Farm, Byfleet, Surrey.

BAXTER, J. E. V..
John E. V. Baxter Ltd.,
28 Priestgate, Peterborough.

BEDFORD, L..
Fisons Fertilizers Ltd., Lincoln.

- BEECH, C. R.
Plant Protection Ltd., Bracknell,
Berks.
- BEEDEEN, PETER
Contracting Representative,
Braithwell, Nr. Rotherham.
- BENSEN, E. R.
Dow Agrochemicals Ltd., London, W.1.
- BERKER, DR.
E. Merck, A.G., Darmstadt, Germany.
- BILLITT, A. M.
Boots Pure Drug Co. Ltd.,
Nottingham.
- BIRD, J.
Fisons Farmwork Ltd., Harston,
Cambs.
- BIRD, MISS MARJORIE L.
William Pearson Ltd., Hull.
- BJERRING, JOHANNES
Elias B. Muus, Odense, Denmark.
- BONDY, DR. H. F.
Coalite & Chemical Products Ltd.,
Chesterfield.
- BOGGART, Ir. K.v.d.
N.V. Fabriek van Chemische
Producten,
Baarn, Holland.
- BOON, DR. W. R.
Plant Protection Ltd., Bracknell,
Berks.
- BOOTH, W.
May & Baker Ltd., Dagenham, Essex.
- BOS, H. D.
F. Bos Ltd., Gedney, Nr. Spalding,
Lincs.
- BOWERMAN, F. G.
Baywood Chemicals Ltd.,
Regional Branch,
Aylesbury, Bucks.
- BOYLE, P. J.
Agricultural Research Council Unit
of Experimental Agronomy,
Oxford.
- BRACEY, PAUL
Consultant Biologist, Salisbury,
Wilts.
- BRADFORD, M. S.
Bradford & Sons Ltd., Yeovil, Som.
- BREESE, T. C.
Du Pont Company (United Kingdom) Ltd.,
London, S.W.1.
- BROOKES, R. F.
Boots Pure Drug Co. Ltd.,
Nottingham.
- BROOKES, R. H.
R. H. Brookes Ltd., Evesham, Worcs.
- BROWN, J.,
Fisons Farmwork Ltd., Harston,
Cambs.
- BROWN, QUINTIN
Scottish Agricultural Industries
Ltd.,
Perth.
- BROWN, P. H.
Efford Experimental Horticultural
Station, Hants.
- BUCHHOLTZ, DR. P. K.
Weed Society of America.
- BUCLON, FRANCIS
Compagnie Pechiney,
23, rue Balsac, Paris (8e).
- BUDDEN, MICHAEL
Dunns Farm Seeds Ltd.,
Salisbury, Wilts.
- BUGGE, E. T.
Bugges Insecticides Ltd.,
Sittingbourne.
- BULL, A. W.
Boots Pure Drug Co. Ltd.,
Nottingham.

BUNN, F. E.
The Murphy Chemical Co. Ltd.,
Wheatthampstead, St. Albans, Herts.

BUNTING, J. P.
Professor of Agricultural Botany,
Reading University.

BURREE, J. P.
Manor Farm, Byfleet, Surrey.

BUTLER, D.
Lankro Chemicals Ltd., Manchester.

CADE, M. C.
Cleanacres Ltd., Cheltenham, Glos.

CAMPBELL, C. L.
J. D. Campbell & Sons Ltd.,
Manchester.

CAMPBELL, S.
National Agricultural Advisory
Service,
Newcastle Upon Tyne.

CARBONI, DR. GIOVANNI
RUMIANCA, Torino, Italy.

CARPENTER, K.
May & Baker Ltd., Ongar, Essex.

CASELEY, J. C.
Post Graduate Research Student,
Research Station, Bristol.

CAYZER, E. PAUL
Agricultural Services Pty. Ltd.,
28 Bungaree Road, Pendle Hill,
N.S.W., Australia.

CARGILL, D.
Boots Pure Drug Co. Ltd.,
Nottingham.

CENSI, DR. G.
Societa Italo Americana Prodotti
Antiparassitari, Naples.

CHARMET, FRANCISQUE
Societe Rhone-Poulenc,
21 rue Jean-Goujon, Paris 8e.

CHEESMAN, DR. E. E.
Agricultural Research Council,
London.

CHANCELLOR, R. J.
Weed Research Organisation, Oxford.

CHANCELLOR, N.
May & Baker Ltd., Dagenham, Essex.

CHIPPENDALE, R. R.
Shell Chemical Co. Ltd.,
London, W.1.

CHERRY, MISS MARY
Journalist, Farmer & Stock-Breeder,
London, S.E.1.

CICCCA, BALDO
Via Vigna 6, Milano, Italy.

CLARE, K. E.
Road Research Laboratory,
Harmondsworth.

CLARKE, F. C.
May & Baker Ltd., Dagenham, Essex.

CLARK, G.
Plant Pathology Laboratory,
Harpenden.

CLARKE, T.
Vitax Limited, Ormskirk, Lancs.

CLAY, S.
John Swan Ltd., Bristol, 1.

CLIFTON, W. N.
Lincs Aerial Spraying Co., Boston.

COLEMAN, F. T.
The Dorman Sprayer Co. Ltd.,
Cambridge.

CONRAD, GUNTER
CELA G.m.b.H., Ingelheim/Rhein,
Germany.

COON, EDWARD T.
Dow Chemical International Ltd.,
S.A.,
Zuric, Switzerland.

COOKE, FRANCIS C.
Editor, World Crops, London, N.W.1.

COCMBE, AUGUSTUS
Nitrate Corporation of Chile Ltd.,
20-24 Ropemaker St., London, E.C.2.

COOPER, MISS JOAN
17, Crookhill Road,
Conisbrough, Nr. Doncaster.

COSLETT, T. A.
Fisons Pest Control Ltd., Harston.

COUTTS, D. L.
The Fullers' Earth Union Ltd.,
Redhill.

COWAN, W. T.
Farm Protection Ltd., Beverley.

COWART, DR. L. E.
Du Pont de Nemours International
S.A.,
Geneva.

COX, J.
Fisons Pest Control Ltd., Harston.

CRAMOND, ROBERT
Scottish Agricultural Industries
Ltd.,
Edinburgh.

CRAMP, KENNETH V.
National Agricultural Advisory
Service,
Cambridge.

CROWDY, S. H.
Plant Protection Ltd., Bracknell.

CUDMORE, D. J.
Crop Protection (Grantham) Ltd.,
Grantham.

CUNNINGHAM, F. J.
Imperial Chemical Industries Ltd.,
London.

CUSSANS, G. W.
Norfolk Agricultural Station,
Norwich.

DAAMS, J.
N.V. Philips-Duphar,
Boekestejn, S-Graveland, Holland.

DADD, C. V.
National Agricultural Advisory
Service,
Cambridge.

DASH, G. R.
The Murphy Chemical Co. Ltd.,
Wheathampstead, St. Albans, Herts.

DAVIES, G. E.
Hill Farming Research Organisation,
Edinburgh, 12.

DAVIES, J.
National Agricultural Advisory
Service,
Aberystwyth.

DAVIES, J. C.
NAAS, Camborne, Cornwall.

DAVISON, JOHN G.
University of Nottingham School of
Agriculture,
Loughborough.

DAYUS, C. V.
Agricultural Advisor, New Zealand
Government Offices,
London.

DEAKIN, M. A. B.
Beecham Foods Ltd., Coleford, Glos.

DETROUX, LOUIS
Station de Phytopharmacie de l'Etat
a Gembloux, Belgium.

DEVERY, COLIN M.
Metallurgical Chemists Ltd., London.

DEWEY, MISS ROSEMARY
Fisons Pest Control Ltd.,
Saffron Walden.

DICKENSON, DOUGLAS
Joseph Weil & Son Ltd.,
London, E.C.2.

DODDS, W. H.
45, Frederick St., Edinburgh, 2.